

Spot Filter



Advancing Process Performance



Localized Dust Control

Typical Applications:

- Conveyor dust control
- Elevator dust control
- Bin vent filter
- Mixer dust control

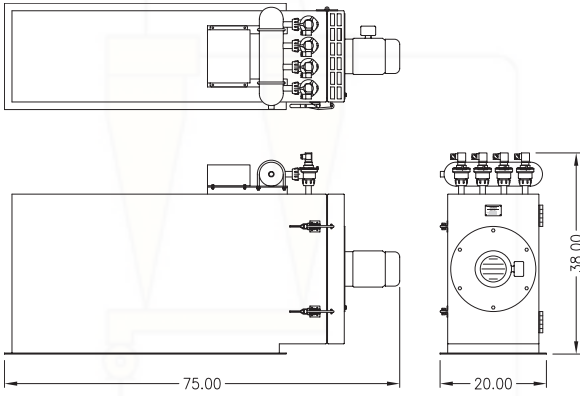

Standard Configuration

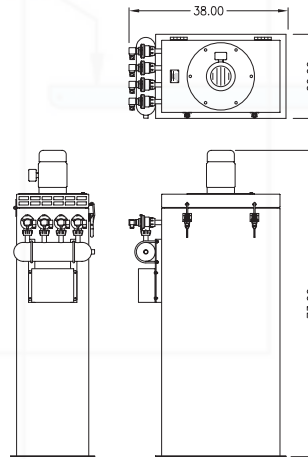

Vertical Configuration

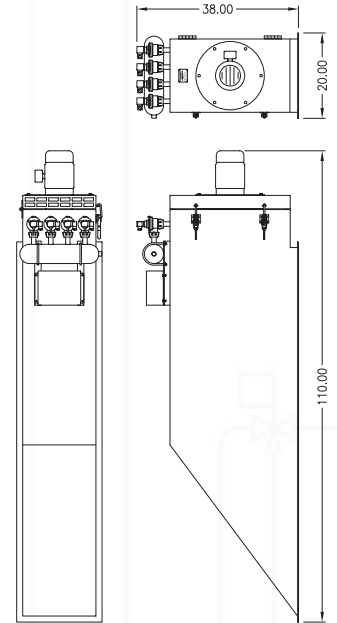

Elevator Vent Configuration

Features

- Compact assembly
- Economical localized dust control
- Dust returned to source for no waste
- Heavy duty construction
- Built-in fan
- Optional fan silencer
- Envelope filter bags
- Sequential timer control for reverse air jet filter cleaning valves
- Each bag is cleaned individually for minimal dust collecting disruption on a cleaning cycle

Standard Size:

- 1 1/2 HP fan
- 800 CFM at 4" w.c.
- 58 ft² filter media

